

**300 SERIES - ROOF EXHAUSTERS  
OPERATION INSTRUCTIONS AND PARTS MANUAL  
MODELS: 307, 309, 310, 312, 315, 318**

Read installation and operation instructions carefully before attempting to install, operate or service DELHI 300 SERIES BLOWERS. Failure to comply with instructions could result in personal injury and/or property damage. Retain instruction for future reference.

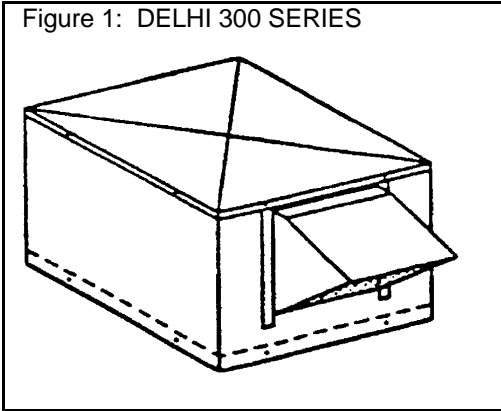

**DESCRIPTION**

DELHI 300 Series Blowers are designed as a quiet and efficient outdoor roof exhauster for high-rise apartments, schools, and commercial industrial applications. These forward curved, double inlet blowers are enclosed in a sturdy insulated steel cabinet c/w a recessed bottom for mounting to an existing curb, with discharge in any of four positions. These blowers are belt drive and may be installed with or without back draft dampers.

Motor, drive installations and servicing may be completed through a removable top cover.

Prelubricated ball bearings, motor bracket, back draft dampers and hardware, motor adjustment hardware and a dynamically balanced wheel are standard equipment. Operating temperature range is -65 to 250 deg. F.

Maximum HP Ratings and Shaft Details			
Model No.	Max. H.P.	Shaft Dia.	Shaft End
307	3/4	3/4	keyway
309	3/4	3/4	keyway
310	1-1/2	3/4	keyway
312	2	3/4	keyway
315	3	1	keyway
318	5	1	keyway

**UNPACKING**

Once the packaging has been removed inspect the unit carefully. Check for loose, missing, or damaged parts. Rotate the wheel by hand to ensure the wheel spins freely. Tighten all set screws.

**GENERAL SAFETY INSTRUCTIONS**

- 1 Always disconnect power source before working on or near a motor or its connected load. Lock the power disconnect in the open position and tag to prevent unauthorized application of power.
- 2 Follow all local and national electrical and safety codes.
- 3 Blower must be electrically grounded. This can be accomplished by using a separate ground wire connected to the bare metal of blower frame, or other suitable means.
- 4 Ensure that the power source conforms to the requirements of your equipment.
- 5 Do not put hands near or allow loose and hanging clothing to be near belts, pulleys, or blower wheel while the unit is running.

**INSTALLATION**

- 1 NOTE: Check the interior of the blower housing. It should be clean and free of debris.  
Rotate the blower wheel by hand. It should not rub against the housing inlet. If rubbing occurs, loosen the set screws on the wheel hub and shift the wheel to obtain clearance. Retighten all set screws.

2 Establish the direction of exhauster discharge. Carefully lift the unit and position over the existing curb. Confirm the unit is properly seated and secure into position by fastening through the 5/16" holes located in the unit's skirt.

3 **OPTIONAL: INSTALLING BACK DRAFT DAMPERS:**  
The first damper to be installed should overlap the discharge baffle with subsequent dampers overlapping the previous damper, until the top of the discharge is reached. Use the #8 x 1-1/4" screws provided to secure the damper into position with the brake facing inward. Insert the screws through the plastic snap bushing located on either side of the blower discharge into the shutter recess. Maintain that each damper installed rotates freely within the snap bushing. (See Figure 2)

4 Insert the exhaust cowl (air direction downward) into the channels provided on either side of the exhaust port.

5 Mount the blower sheave on the blower shaft and tighten its set screw securely on the key of the shaft. (See Table 1 for Drive Data)

6 Mount the motor sheave on the motor shaft. Leave some clearance between the pulley and the motor end bell. Tighten the set screws on the key of the motor shaft.

7 Slide the square head bolts into the channel provided in the motor bracket. Place the motor into position, finger tighten the nuts to temporarily secure the motor. Attach the motor adjustment (belt tension) assembly.

8 With the motor adjusting bolt in its minimum position install the V belt within the sheave grooves. Slide the motor within the motor bracket to ensure proper pulley alignment (see Figure 3). A straight edge across the face of the driven pulley should be parallel to the belt once proper alignment has been achieved. Tighten the nuts on the motor base to anchor the motor position within the bracket.

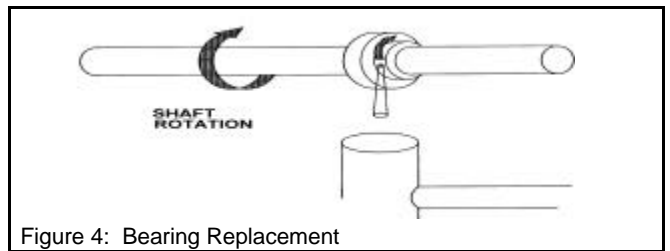
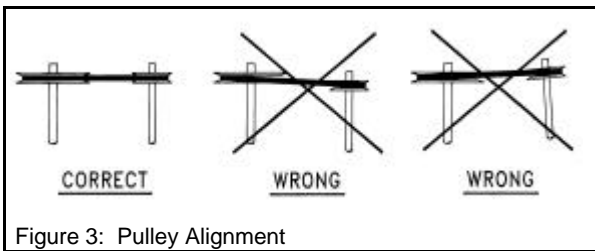
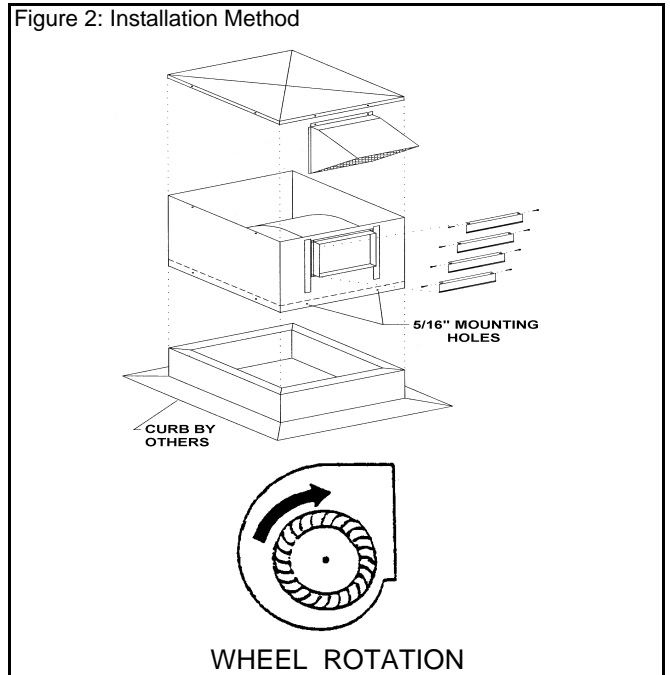

**NOTE:** Pulley alignment may change when adjusting variable pitch pulleys.

9 Adjust belt tension by turning the motor adjustment hook bolt. Ideal belt tension is the lowest tension at which the belt will not slip during start up. A rule of thumb suggests that 3/4" of deflection mid span under medium finger pressure (2-3 lbs.) for every foot of span is approximately proper belt tension. Lock the motor adjustment (belt tension) assembly once proper belt tension has been achieved.

**WARNING: EXCESSIVE BELT TENSION IS THE MOST FREQUENT CAUSE OF BEARING WEAR AND RESULTING NOISE**

10 Before connecting the motor to the electrical supply, check the electrical characteristics and wiring instructions as indicated on the motor nameplate to ensure proper voltage and phase. Make your electrical connections.

**WARNING: A GROUND WIRE MUST BE CONNECTED FROM THE MOTOR HOUSING TO A SUITABLE ELECTRICAL GROUND**

Table 1: Drive Table

NOTE TO CONVERT:

A) 48 FRAME TO 56/143T/145T FRAME ADD 1" TO BELT LENGTH

B) 56/143T/145T FRAME TO 182T/184T FRAME ADD 2" TO BELT LENGTH

C) 4L TO B BELTS SUBTRACT 3" FROM THE BELT LENGTH (eg.: 4L48 EQUIVALENT TO A B45 - RPM WILL VARY SLIGHTLY)

Motor Pulley	Blower Pulley	RPM Range	307	309	310	312	315	318
			48 FRAME	48 FRAME	56/143T/145T FRAME	56/143T/145T FRAME	56/143T/145T FRAME	182T/184T FRAME
3-1/4"  3/4 HP MAX.	12	333 - 455	---	---	---	---	4L58	---
	10	401 - 548	---	---	---	4L51	4L55	---
	9	447 - 611	---	---	---	4L49	---	---
	8	505 - 690	4L37	4L41	4L44	4L47	---	---
	7	580 - 792	4L36	4L40	4L42	4L46	---	---
	6	680 - 929	4L34	4L38	4L40	---	---	---
IVL34	5	824 - 1125	4L33	4L36	---	---	---	---
	BK160H	252 - 309	---	---	---	---	---	---
	BK140H	310 - 356	---	---	---	---	---	---
	BK130H	357 - 386	---	---	---	---	4L58	4L64
	BK120H	387 - 421	---	---	---	---	4L57	B61
	BK110H	422 - 464	---	---	---	---	4L55	B59
	BK100H	465 - 515	---	---	---	4L49	4L53	B58
	BK90H	516 - 579	4L38	4L41	4L44	4L48	B50	B56
	BK80H	580 - 663	4L36	4L40	4L42	4L46	B49	B54
	BK70H	664 - 773	4L34	4L38	4L41	4L45	B47	B53
	BK60H	774 - 963	4L33	4L37	4L39	B41	B45	B51
IVP44	BK50H	964 - 1203	4L31	4L35	B36	B40	---	---
	BK40H	1204 - 1504	4L30	4L34	B34	---	---	---
	BK130H	491 - 543	---	4L49	4L52	4L56	B58	B64
	BK120H	544 - 592	4L44	4L48	4L50	4L54	B56	B62
	BK110H	593 - 648	4L42	4L46	4L49	4L52	B55	B61
	BK100H	649 - 716	4L41	4L44	4L47	4L51	B53	B59
	BK90H	717 - 802	4L39	4L43	4L45	B48	B51	B57
	BK80H	803 - 911	4L37	4L41	4L44	B46	B50	B56
	BK70H	912 - 1053	4L36	4L39	B40	B44	B48	---
	BK60H	1054 - 1281	4L34	4L38	B39	---	---	---
	BK50H	1282 - 1567	4L32	4L36	B37	---	---	---
BK40H	1568 - 1960	4L31	4L35	---	---	---	---	

**OPERATION**

- 1 After electrical connections are completed, energize the unit momentarily and ensure that the rotation of the wheel is correct (see Figure 2). Apply full power.
- 2 With the air system in full operation, all ducts attached and top cover in place, measure current input to the motor and ensure that it is less than the rated full load motor amperage.
- 3 Proper adjustment to the belt tension is critical for quiet efficient operation.
- 4 Replace the top cover for proper operation of this unit. NOTE: When replacing the top cover ensure that the spring steel nut is positioned over the top flange of the cowl such that when the top cover has been replaced, the two fasteners secure the cowl and top cover to the cabinet (See Figure 6).

**MAINTENANCE**

**WARNING: DISCONNECT POWER SUPPLY BEFORE SERVICING THE BLOWER**

- 1 Inspect and tighten all bearing collar and wheel set screws after the first 50 to 100 hours of operation and periodically thereafter.
- 2 Follow motor manufacturer's instructions for motor lubrication. Remove any excess lubrication.
- 3 Check the drives.
  - a. Tighten set screws on sheaves, wheel and bearing locking collars.
  - b. Check belt tension and alignment.
  - c. Replace cracked or worn belts.
- 4 Check wiring to be sure it is secure and well insulated.
- 5 Blower bearings are permanently lubricated and require no further lubrication.
- 6 Inspect V-belts for wear and proper tension. If it is necessary to replace one belt on a multiple belt drive, replace all the belts with a matched set. Do not use belt dressing.
- 7 Clean the blower wheel periodically. Material build up on the blades can cause wheel imbalance which may result in wheel or bearing failure.
- 8 To reinstall replacement ball bearings press the locking collar against the inner ring of the bearing and turn in the direction of the shaft rotation until engaged. Insert a drift pin into the pin hole and tap lightly to set. Tighten set screw on locking collar firmly (see Figure 4).
- 9 Should further service to the blower be necessary, refer to the exploded view illustration. (See Figure 5).

**DELHI INDUSTRIES INC. WARRANTY**

Delhi Air Moving Products are guaranteed for a period of one year against manufacturing defects in material and workmanship when operating under normal conditions. Liability is limited to the replacement of defective parts. Labour and transportation costs are not included.

**FIGURE 5:  
300 SERIES EXPLODED VIEW**

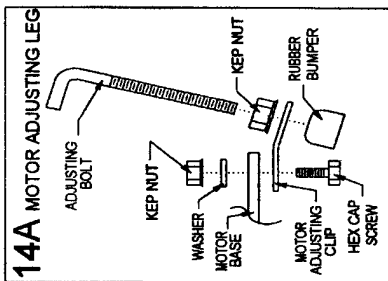
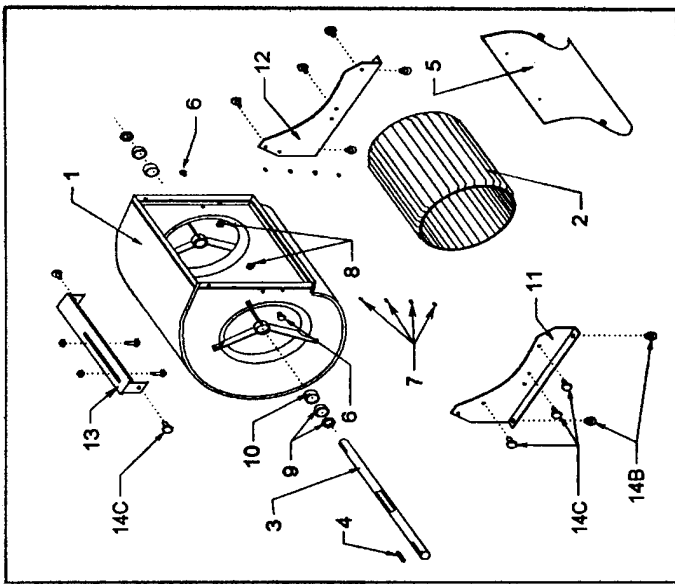

MODEL 318 MOTOR MOUNT  
USES 2 MOTOR BRACKETS

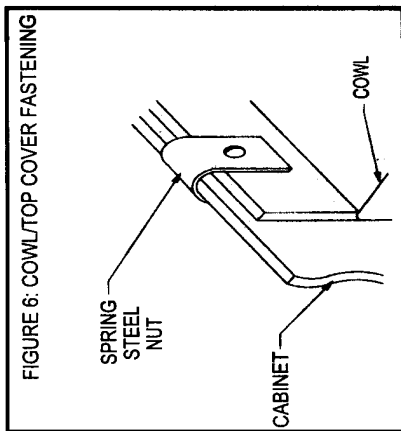
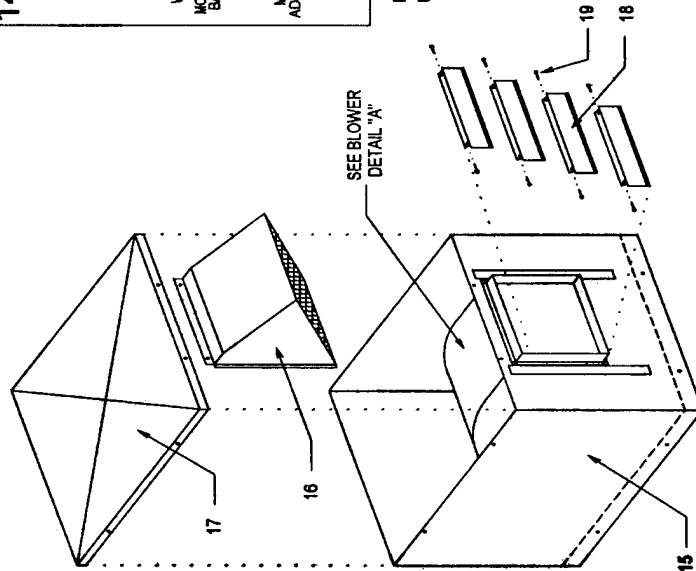

**FIGURE 6: COWLTOP COVER FASTENING**

**PARTS LIST**

- 1. HOUSING
- 2. WHEEL
- 3. SHAFT
- 4. SHAFT KEY
- 5. BAFFLE (CUTOFF)
- 6. #8 - 15x3/4" SHT METAL SCREWS (MODELS 307 - 312)  
#10 - 24x3/8" SCREW (MODELS 315, 318)
- 7. 10 - 24 SQUARE NUT (MODELS 315, 318 ONLY)
- 8. PLASTIC SNAP BUSHING
- 9. BALL BEARING c/w ECCENTRIC COLLAR
- 10. RUBBER BEARING CUP
- 11. BASE SIDE (RIGHT)
- 12. BASE SIDE (LEFT)
- 13. MOTOR BRACKET
- 14. HARDWARE
  - a) MOTOR ADJUSTING LEG
  - b) RUBBER GROMMET
  - c) 1/4"x20 SELF TAPPING SCREW
- 15. CABINET
- 16. COWL c/w BIRDSCREEN
- 17. TOP COVER
- 18. BACK DRAFT DAMPER
- 19. DAMPER SCREW #8x1-1/4"