

**400/800/900 SERIES – UTILITY BLOWERS**

**OPERATION INSTRUCTIONS AND PARTS MANUAL**

**MODELS: 407 through 425, 809 through 818, 809-2 through 818-2, 907, 909-7, 909, 910-8, 910, 912-9, 912, 915-10, 915, 918-13, 918, 920, 922, 925, 927, 930, 933, 936**

**GENERAL SAFETY**

Rotating parts on fans should not be exposed. Where these components are not protected by ductwork, cabinets or covers, appropriate guards should be employed to restrict exposure to rotating parts. Access doors should not be opened with the fan operating to avoid foreign objects being drawn into the system. On initial start-up a careful inspection should be carried out to ensure no foreign material is present which could become airborne in the system.

Read installation and operation instructions carefully before attempting to install, operate or service Delhi 400/800/900 Series Blowers. Failure to comply with instructions could result in personal injury and/or property damage. Retain instructions for future reference.

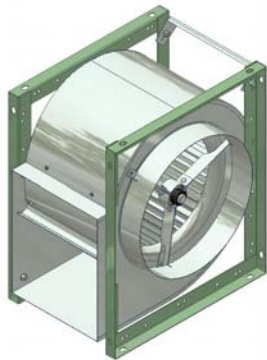

**FIG. 1: 400**

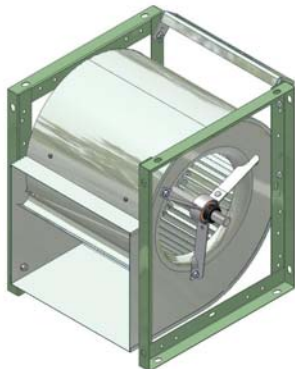

**FIG 2: 800**

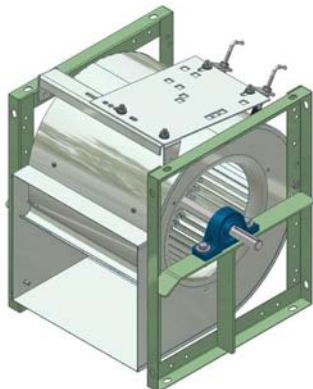

**FIG 3: 900**

MODEL	MAX. HP	SHAFT DIA.	WEIGHT (lbs.)
407	1	3/4"	16
409	2	3/4"	23
410	2	3/4"	26
412	2	3/4"	30
415	3	1"	56
418	5	1"	57
420	7-1/2	1-3/16"	189
422	7-1/2	1-3/16"	214
425	10	1-3/16"	252
MODEL	MAX. HP	SHAFT DIA.	WEIGHT (lbs.)
809	3	3/4"	28
810	3	3/4"	32
812	3	1"	43
815	3	1"	67
818	5	1"	125
809-2	3	3/4"	95
810-2	3	3/4"	112
812-2	3	1"	130
815-2	5	1"	195
818-2	5	1"	302
MODEL	MAX. HP	SHAFT DIA.	WEIGHT (lbs.)
907	3	3/4"	28
909-7	3	3/4"	34
909	3	3/4"	40
910-8	3	3/4"	43
910	5	1"	52
912-9	5	1"	56
912	5	1"	69
915-10	5	1"	72
915	5	1"	87
918-13	5	1-3/16"	96
918	10	1-3/16"	120
920-18	15	1-7/16"	212
920	15	1-7/16"	220
922	15	1-7/16"	245
925	15	2-3/16"	297
927	50	2-7/16"	385
930	60	2-11/16"	470
933	100	2-11/16"	590
936	100	2-11/16"	640

## GENERAL

Inspect unit for damage, report any shipping damage to carrier. Check all fasteners and re-tighten as required. Rotate the blower wheel by hand to ensure free rotation. If rubbing occurs, loosen the set screw(s), re-position the wheel to the shaft centre, re-tighten set screw(s).

## MOTORS, PULLEYS AND BELTS (SEE TABLE 1)

1. Prior to installing the motor, ensure the wheel rotates freely by turning by hand. If rubbing occurs loosen the wheel set screws and re-position the wheel to the centre of the shaft. Re-tighten all set screws.
2. Establish the preferred discharge direction and secure by fastening through the frame holes located at the bottom of the blower.
3. Mount the blower pulley on the blower shaft and tighten the set screw securely on the key of the shaft.
4. Mount the motor pulley on the motor shaft. Leave some clearance between the pulley and the motor end bell.
5. Position the square head bolts in the groove of the motor mounting bracket and install the motor loosely on the bracket using the hardware provided. Bolt the motor adjusting leg to shaft side of the motor base. **Note: This may not be applicable if an optional motor plate was purchased (Figure 6).**
6. With the adjusting bolt in the minimum position, install the V-belt(s) within the sheave grooves. Position the motor on the motor bracket to ensure proper pulley alignment (Figure 5) and tighten the motor mounting hardware to secure the motor position. (A straight edge across the face of the driven pulley should be parallel to the belt once proper alignment has been achieved). **Note: Adjustments in the variable speed pulley require pulley re-alignment.**
7. Tighten the adjusting bolt to tension the V-belt and lock in place using the keps nut. (Figure 4) **Note: Ideal belt tension is the lowest tension at which the belt will not slip during start up.**

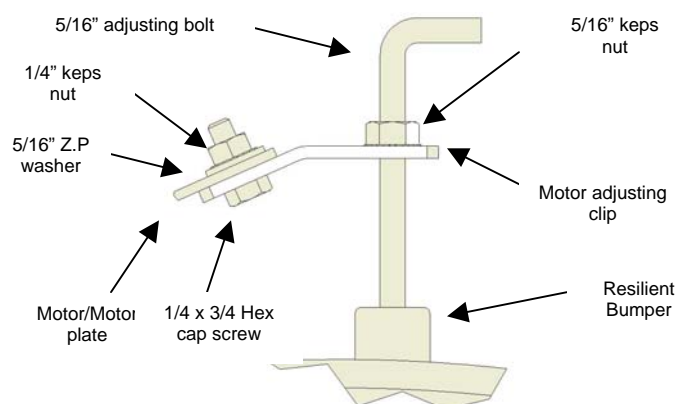

**FIGURE. 4: MOTOR MOUNTING**

**WARNING: Excessive belt tension is the most frequent cause of bearing wear and resulting noise. Proper belt tension is critical for quiet efficient operation.**

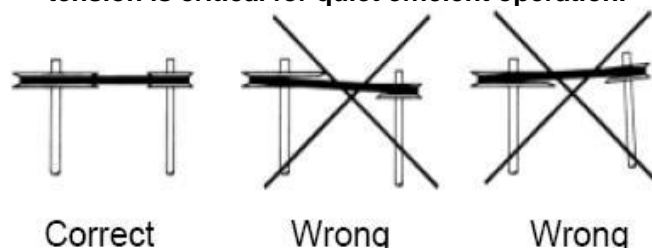

**FIGURE. 5: PULLEY ALIGNMENT**

## ELECTRICAL

**WARNING: Ensure power supply is disconnected and locked out prior to making electrical connections.**

Before connecting the motor to the electrical supply, check the electrical characteristics and wiring instructions as indicated on the motor nameplate or as shown below. Complete electrical connections as indicated.

**WARNING: A ground wire must be connected from the motor housing to a suitable electrical ground.**

## OPERATION

1. Complete the electrical connections, remove the belts, energize the unit momentarily to ensure proper motor rotation. Re-install belts.
2. Apply full power.
3. With all ducts attached, and the air system in full operation, measure the motor current and ensure that it is less than the rated full load motor amperage as indicated on the motor nameplate.

## MAINTENANCE

### Ensure power supply is disconnected and locked out prior to performing maintenance

1. Inspect and tighten all bearing collar and wheel set screws after the first 50 to 100 hours of operation and periodically thereafter.
2. Follow the motor manufacturer's instructions for motor lubrication. Remove any excess lubrication.
3. Check the drives.
  - a. Tighten the set screws on pulleys, wheel and bearing locking collars.
  - b. Check the belt tension and alignment.
  - c. Replace cracked or worn belts.
4. Blower bearings are permanently lubricated and require no further lubrications.
5. Inspect V-belts for wear and proper tension. If it is necessary to replace one belt on a multiple belt drive, replace all the belts with a matched set. Do not use belt dressing.
6. Clean the blower wheel periodically. Material build up on the blades can cause wheel imbalance which may result in wheel or bearings failure.
7. To reinstall replacement ball bearings on spider bearing bracket assemblies, press the locking collar against the inner ring of the bearing and turn in the direction of the shaft rotation until engaged. Insert a drift pin into the pin hole and tap lightly to set. Tighten set screw on locking collar firmly. If replacing the pillow block bearings, simply loosen the set screws and remove the mounting hardware. When re-installing, Bolt the pillow block to the T-bar support, then position the set screw to be parallel and on top of the key stock of the shaft. Torque set screw to specified values.
8. Spider bracket bearings come pre-lubricated from the manufacturer, and require no re-lubrication. Pillow block bearings are pre-lubricated by the manufacturer. Generally, these bearings should be lubricated at six to twelve month intervals. The recommended lubricant is Shell Alvania #2 or S3. A small amount of grease should be added slowly when the shaft is rotating. Note: Over greasing may cause damage to the bearing. Avoid rupturing the bearing seal.
9. Should further service to the blower be necessary, refer to the exploded view illustration (see Figure 7).

## OPTIONAL MOTOR MOUNTING (FIGURE 6)



**3HP MOTOR PLATE**



**5HP MOTOR PLATE**

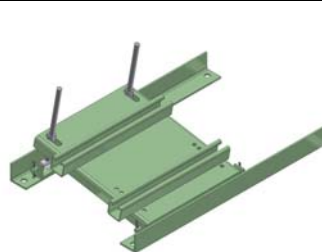

**1-15 HP MOTOR PLATE**

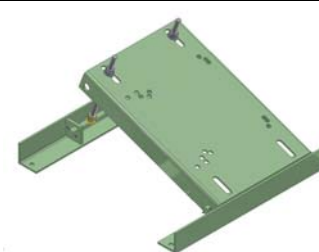

**20-50 HP MOTOR PLATE**

PARTS LIST	
1. Framework	5. Bearing Bracket
2. Baffle	6. Ball Bearing Assy
3. Housing	7. Shaft
4. Wheel	8. Motor Bracket

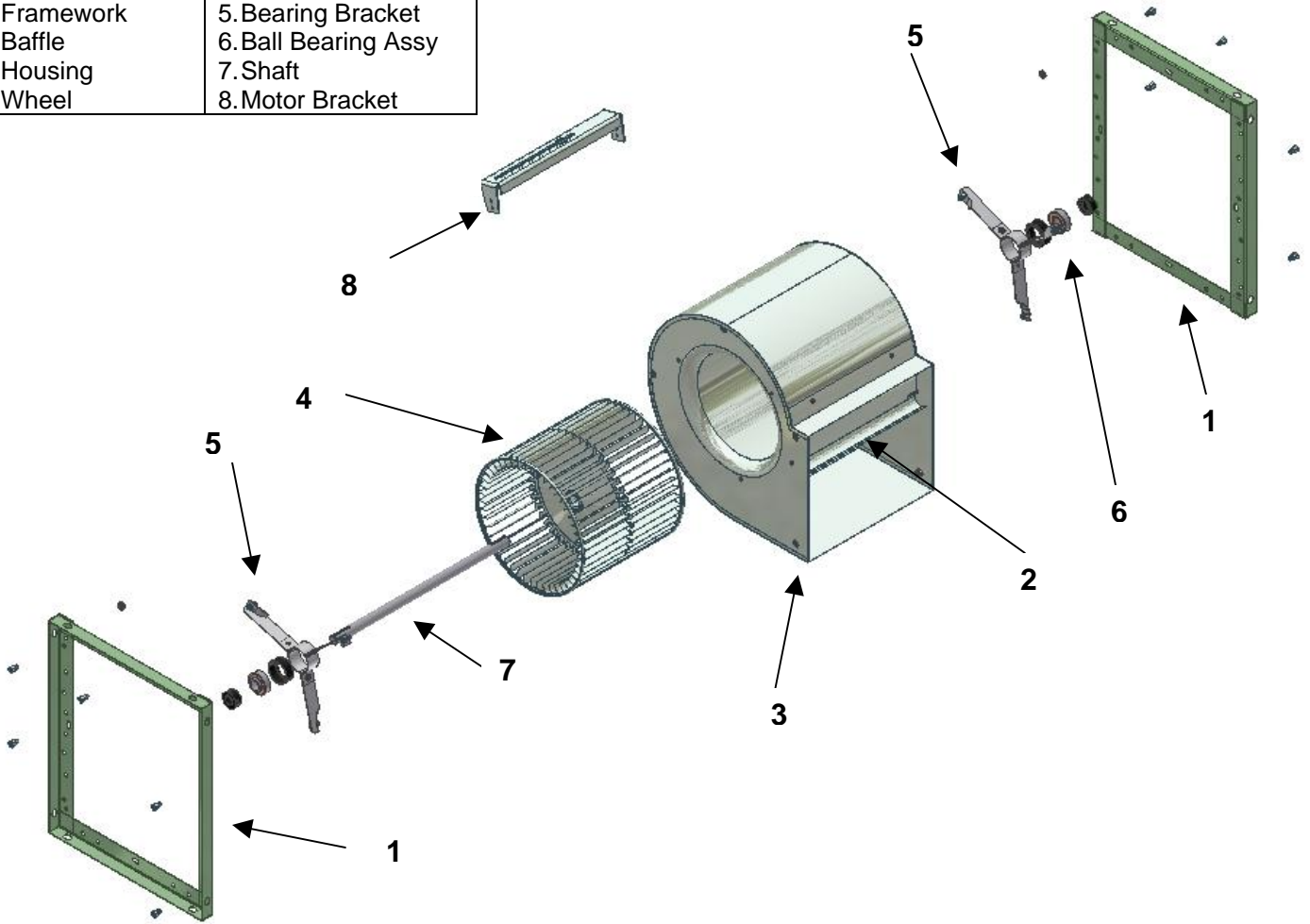

**FIGURE 7: EXPLODED VIEW (800 series)**

**\*\*Refer to Figure 3 for an illustration on T-Bar's and Pillow block bearings.**

## WARRANTY

Delhi Industries Inc. Air Moving Products are guaranteed for a period of one year against manufacturing defects in material and workmanship when operating under normal conditions. Liability is limited to the replacement of defective parts. Labour and transportation costs are not included.